

RESPECTIVE END ORIENTATIONS

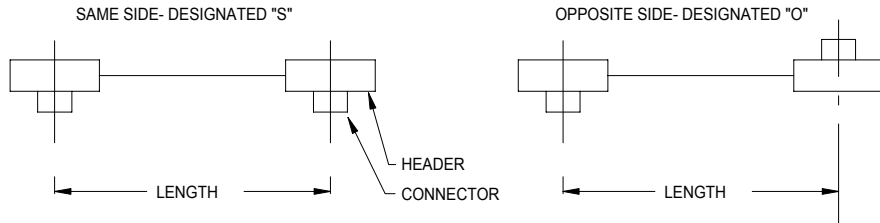

CONNECTOR ORIENTATION WITH RESPECT TO CABLE

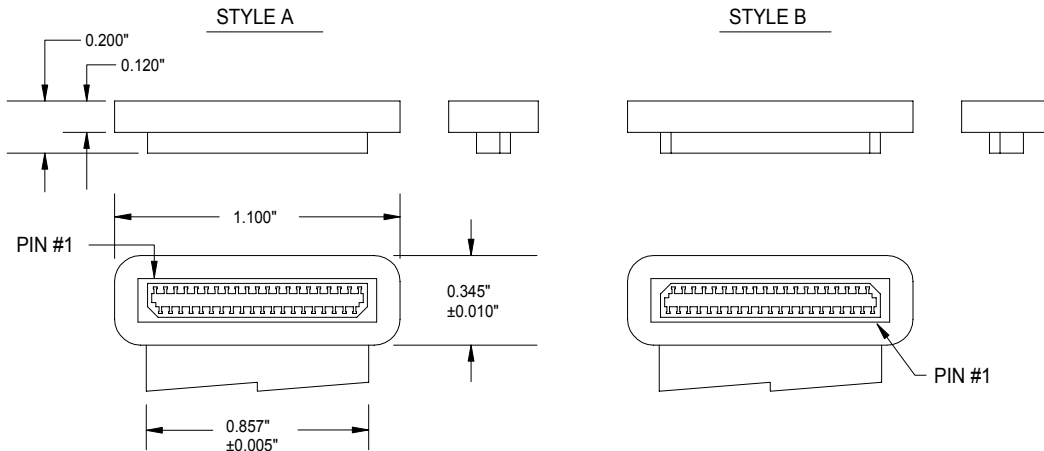

NOTES

- 1) INSULATION: 0.002" THICK POLYESTER
- 2) CONDUCTORS: 0.003" X 0.011" (39 PLACES)
0.003" X 0.026" (2 PLACES, OUTER)
- 3) HEADER MATERIAL: DUPONT 612 NYLON
- 4) CONNECTOR: HIROSE P/N DF9C-41S-1V
- 5) CABLE RATING: AWM STYLE 20890 105°C, 90V, VW-1
- 6) CABLE THICKNESS= 0.010"±0.002"
- 7) CABLE WIDTH= 0.857"±0.005"

REVISIONS			
LTR	DESCRIPTION	DATE	APPRVD
-	INITIAL RELEASE	1/16/98	
A	ADDED .345" DIMENSION TO HEADER	4/1/99	
B	ADDED EXAMPLE P/N	3/14/02	C.D.

CREATING A PART NUMBER

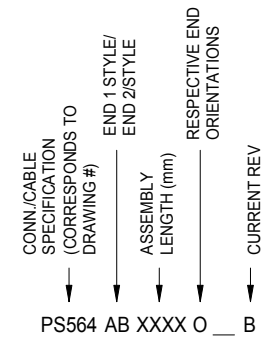

i.e. PS564AA02540 B

EXAMPLE GIVEN INDICATES A 41 POS. CABLE ASSEMBLY TERMINATED WITH HIROSE CONNECTORS (P/N DF9C-41S-1V) IN WHICH PIN #1 TRACES TO PIN #1, ASSEMBLY IS 10.000" IN LENGTH, AND CONNECTORS ARE ON OPPOSITE SIDES OF CABLE AS DEFINED AT LEFT.

TOLERANCES	MATERIAL		P ARLEX CORPORATION One Parlex Place Methuen, Ma 01844 LAMINATED CABLE DIVISION			
	DR	DATE				
.XXX ±	C.Dobens	1/16/98	END DETAILS FOR TERMINATING CABLE WITH 41 POS. S/M HIROSE CONNECTORS			
.XX ±	CHK					
ANGLES ±	ENG	1/16/98	SIZE	FSCM	PS-564	REV
	APPD		B	18377		B
			SCALE	2:1		SHEET 1 OF 1